

# METERING & SHUT OFF VALVES

## N100 SERIES

The N100 Series straight pattern needle valves with sight are ideally suited for vertical inline installation requiring controlled visible fluid metering. Knurled wheel provides for smooth, accurate adjustments of flow rate. Drip feed rate is adjustable from full orifice flow to complete shut-off. Flow is readily visible through large sight window. Pressure units supplied with non-vented sights. Gravity feed valves are furnished with a vented sight chamber, provided by a split in the gasket above the sight glass.

### Standard Features:

- 1/8, 1/4, 3/8 or 1/2 inch NPTF connections
- Available in either male or female connections

### Standard Materials:

- Precision machined from brass bar stock.
- Buna N seals.
- Gage glass sight.
- Pipe threads are dryseal

### Pressure Rating:

- Maximum operating pressure 125 PSI (862 kPa) to orifice

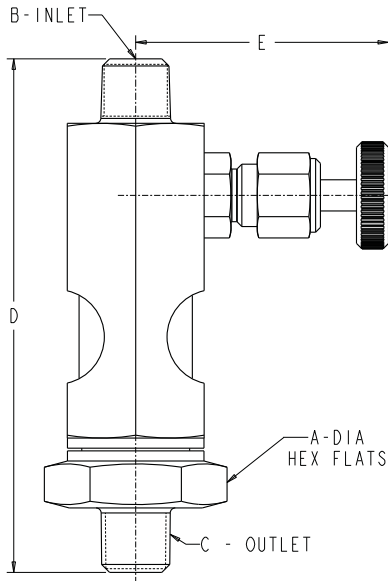

N100 Series							
Part No.		A	Orifice	B	C	D	E
Gravity	Pressure	Hex Dia. inches (mm)	inches (mm)	Inlet	Outlet	inches (mm)	inches (mm)
N102-01	—			1/8 M	1/8 M	3.03 (76.96)	
N102-02	N102-12			1/4 M	1/4 M	3.41 (86.61)	
N102-03	—	.81 (20.57)	.09 (2.39)	1/8 F	1/8 F	2.72 (69.09)	1.50 (38.10)
N102-04	N102-14			1/4 F	1/4 F	2.97 (75.44)	
N102-06	—			1/4 M	1/4 T	3.44 (87.38)	
N103-01	—	.94 (23.88)	.11 (2.77)	3/8 M	3/8 M	3.56 (90.42)	1.75 (44.45)
N103-02	—			3/8 F	3/8 F	3.25 (82.55)	
N104-01	—	1.06 (26.92)	.15 (3.86)	1/2 M	1/2 M	3.94 (100.08)	1.75 (44.45)
N104-02	N104-12			1/2 F	1/2 F	4.62 (117.35)	

**MODIFICATIONS AVAILABLE MADE TO ORDER - CONSULT OUR FACTORY  
(MINIMUM ORDER MAY BE REQUIRED)**

Dimensions and specifications are subject to change without notice. Not all items are Made-To-Stock, contact us for availability.

04/15

Ph : 920-682-6877  
Fx : 920-684-7210



sales@ldi-industries.com  
www.ldi-industries.com