

GAS ENGINE ADAPTERS

PEM-HH FLANGE

Pump Gas Engine Adapters (Bell Housings) are designed to assure proper shaft alignment between the gasoline engine and your hydraulic pump. They also reduce assembly cost over using a foot mounting bracket or riser.

Standard Features:

- Light weight - High strength
- Drive coupling access hole
- Safety orange removable cover for coupling access hole
- Gas Engine Adapters are designed to be used with gas engines with horizontal shafts only.

Standard Material:

- Cast Aluminum

WARNING:

- To avoid possible injury, access hole cover must be in place during operation

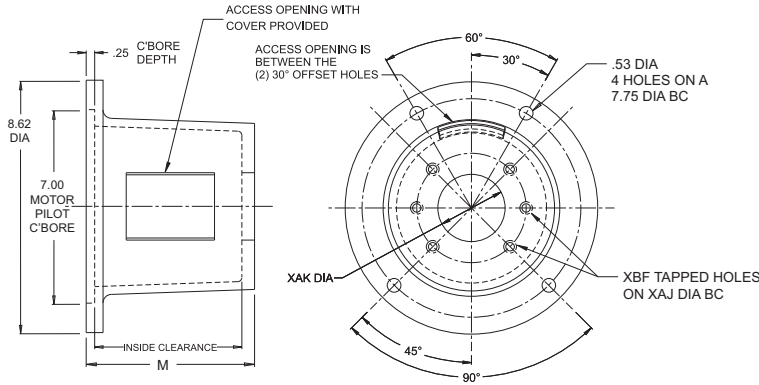

NOTE: All dimensions are inches.

Gas Engine Adapter - PEM-HH Flange (inches)								
Part No.	Pump Type	Pump Mounting Flange	MAX Coupling Dia	XAJ Bolt Circle	XAK Pump Pilot	XBF Mounting Holes (NC)	M Face to Face	Inside Clearance
6017	SAE A	2 Bolt	4.00	4.19	3.25	3/8-16	5.62	4.50

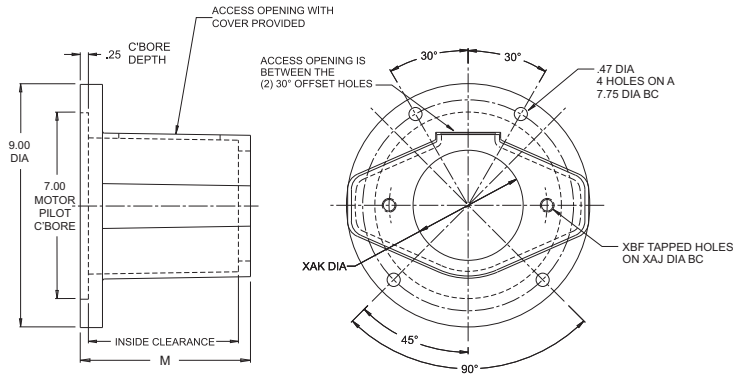

NOTE: All dimensions are inches. Standard metric series pump flanges also available - Consult factory.

Gas Engine Adapter - PEM-HH Flange (inches)								
Part No.	Pump Type	Pump Mounting Flange	MAX Coupling Dia	XAJ Bolt Circle	XAK Pump Pilot	XBF Mounting Holes (NC)	M Face to Face	Inside Clearance
196199	SAE A	2 Bolt	3.50	4.19	3.25	3/8-16	7.00	5.12
196399	SAE B	2 Bolt 4 Bolt	3.50	5.75 5.00	4.00	1/2-13	7.00	5.12
196599	SAE C	2 Bolt	3.50	7.12	5.00	5/8-11	7.00	5.12

Dimensions and specifications are subject to change without notice. Not all items are Made-To-Stock, contact us for availability.

11/15

Ph : 920-682-6877
Fx : 920-684-7210



sales@ldi-industries.com
www.ldi-industries.com

GAS ENGINE ADAPTERS

GAS ENGINE MOUNTING FLANGE INFORMATION

Standard Features:

- Decrease assembly time - bolt mount to side of gas engine
- Made of lightweight but strong cast aluminum
- Proper shaft alignment assured
- Reduced cost - no need for foot brackets, shims or risers
- Provide a clean, neat appearance for your finished product
- Gas Engine Adapters are designed to be used with gas engines with horizontal shafts only.

Easy Assembly Pump to Gas Engine:

- Place coupling half for engine on engine shaft and lightly tighten set screw
- Mount pump to pump end of gas engine adapter
- Place coupling half for pump on pump shaft and lightly tighten set screw
- Position coupling insert - Bolt gas engine adapter with pump installed to the face of the gas engine
- Adjust coupling thru access opening - Thoroughly tighten set screws and mounting bolts

PEM-F FLANGE

*Dimensions to be furnished by customer

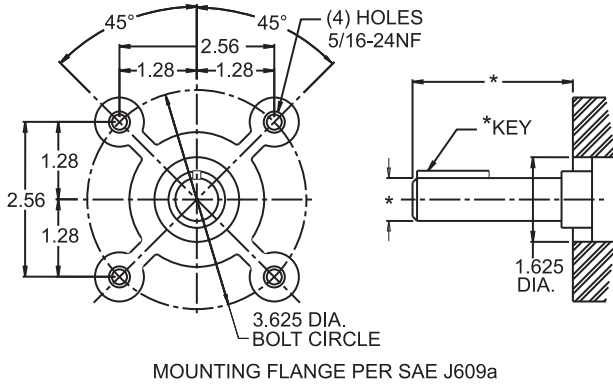

PEM-H FLANGE

*Dimensions to be furnished by customer

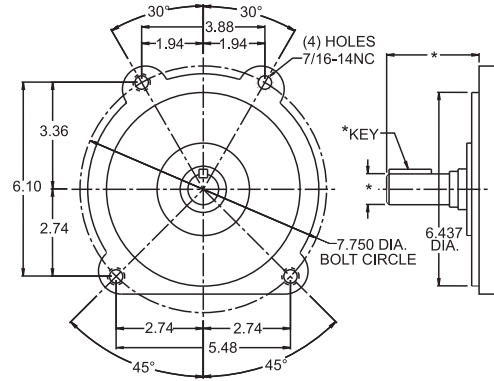

PEM-G FLANGE

*Dimensions to be furnished by customer

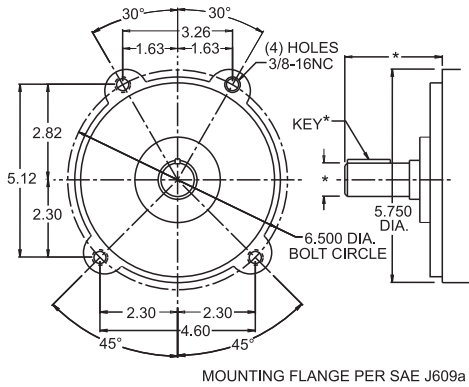

PEM-HH FLANGE

*Dimensions to be furnished by customer

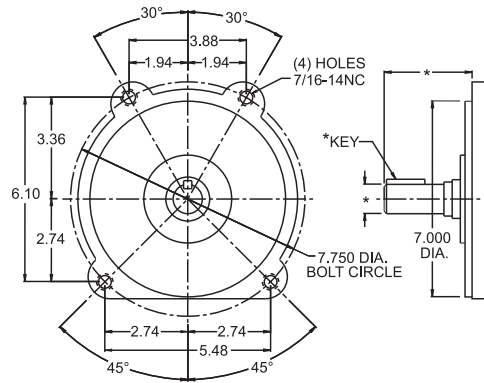

NOTE: All dimensions are inches

Dimensions and specifications are subject to change without notice. Not all items are Made-To-Stock, contact us for availability.

05/23

Ph : 920-682-6877
Fx : 920-684-7210



sales@ldi-industries.com
www.ldi-industries.com