

SIGHT GAGES - CLOSED CIRCUIT

G608 SERIES

The G608 Series front mount closed circuit sight gages provide front viewing of the fluid level clearly delineated by a redline on white background integral to the glass sight all secured within an aluminum body (HIGH-LOW markings). Brass pipe adapters with integral needle valves are provided with the sight gages for direct assembly of the sight gage to NPT couplings. The needle valves allow a user to shut off flow to the sight gage allowing the sight gage to be removed from the reservoir with minimal loss of fluid

Standard Features:

- Front mount
- Fluid level visible from front of gage (.50 inches wide)
- Viewing enhanced by redline on white background integral to sight glass
- Suitable for use with most hydraulic and machine lubricating oils

Standard Materials:

- Aluminum gage body and mounting bolts
- Brass pipe adapters (with needle valves)
- Buna N seals
- Borosilicate glass sight

Temperature and Pressure Ratings:

- Maximum working pressure as noted in table below at 150°F (65°C), no corrosion
- Please refer to Temperature Ratings by Seal Material for additional operating conditions (Appendix RA-5 on page RA-A5)

NOTE:

- Please refer to Appendix RA-7 on page RA-A7 for installation instructions

CAUTION: • Not recommended for use with water, steam, acidic fluids, caustic fluids and volatile fluids

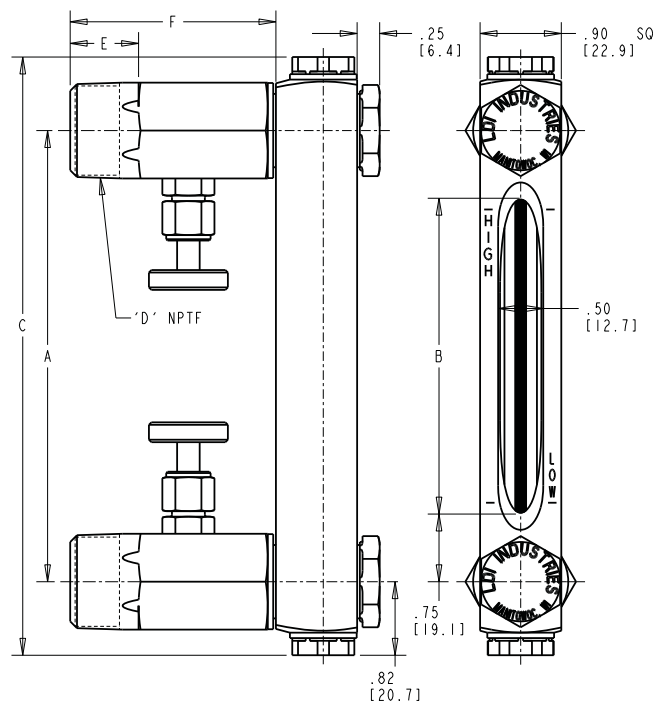

G608 Series			
A inches (mm)	B inches (mm)	C inches (mm)	Max. Work. Pressure PSI (kPa)
10.00 (254.00)	8.50 (215.90)	11.62 (295.15)	275 (1896)
12.00 (304.80)	10.50 (266.70)	13.62 (345.95)	270 (1862)
15.00 (381.00)	13.50 (342.90)	16.62 (422.15)	260 (1793)
18.00 (457.20)	16.50 (419.10)	19.62 (498.35)	240 (1655)
24.00 (609.60)	22.50 (571.50)	25.62 (650.75)	210 (1448)
30.00 (762.00)	28.50 (723.90)	31.62 (803.15)	185 (1276)



Pipe Adapter		
D NPTF	E inches (mm)	F inches (mm)
1/4-18	.57 (14.48)	2.09 (53.09)
3/8-18	.57 (14.48)	2.09 (53.09)
1/2-14	.76 (19.30)	2.28 (57.91)
3/4-14	.76 (19.30)	2.28 (57.91)

NOTE: All dimensions are inches [mm]

ORDERING OPTIONS CODES:

BODY MATERIAL

- A- Aluminum gage body (standard)
- B- Brass gage body (optional)
- S- Steel gage body (optional)
- Y- Stainless Steel gage body (optional)

SEAL MATERIAL

- 1- Buna N seals (standard)
- 2- Butyl seals (optional)
- 3- Viton® seals (optional)
- 4- Ethylene propylene seals (optional)
- 5- Silicone seals (optional)

SPECIFY PIPE THREAD SIZE:

- 2- 1/4 male pipe thread
- 3- 3/8 male pipe thread
- 4- 1/2 male pipe thread
- 5- 3/4 male pipe thread

HOW TO ORDER

EXAMPLE:

G608-10-A-1-4 — 1/2 inch pipe thread
 — Buna N Seals
 — Aluminum gage body
 — 10.00 (254.00 mm) mounting centers
 — Series G608

Dimensions and specifications are subject to change without notice. Not all items are Made-To-Stock, contact us for availability.

02/14

Ph : 920-682-6877
 Fx : 920-684-7210



sales@ldi-industries.com
 www.ldi-industries.com