

SIGHT GAGES - CLOSED CIRCUIT

G617 SERIES

The G617 Series front mount closed circuit sight gages provide front viewing of the fluid level clearly delineated by a redline on white background integral to the sight glass all secured within an aluminum body (HIGH-LOW markings). Brass pipe adapters are provided with each sight gage for assembly of the sight gage to NPT couplings. Integral to the sight gage body is a wetted dial thermometer providing direct reading of the fluid temperature.

Standard Features:

- Front mount
- Fluid level visible from front of gage (.50 inches wide)
- Viewing enhanced by redline on white background integral to sight glass
- 1.38" diameter dual scale dial thermometer, 50° to 300°F and 10° to 150°C
- Suitable for use with most hydraulic and machine lubricating oils

Standard Materials:

- Aluminum gage body and mounting bolts
- Brass pipe adapters
- Buna N seals
- Borosilicate glass sight

Temperature and Pressure Ratings:

- 125 psi (862 kPa) maximum working pressure at 150°F (65°C)
- Please refer to Temperature Ratings by Seal Material for additional operating conditions (Appendix RA-5 on page RA-A5)

NOTE:

- Please refer to Appendix RA-7 on page RA-A7 for installation instructions

CAUTION: • Not recommended for use with water, steam, acidic fluids, caustic fluids and volatile fluids
 • If aluminum construction is selected for a water application, anodizing is recommended
 • Reservoir must be drained to remove dial thermometer or loss of fluid will occur

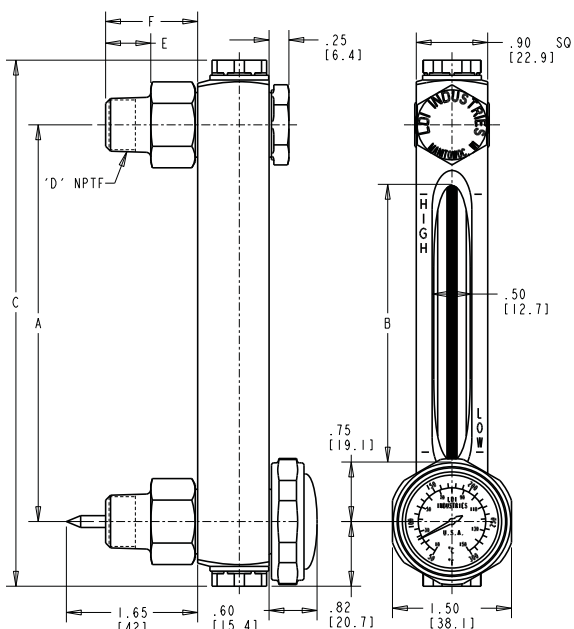

NOTE: All dimensions are inches [mm]

ORDERING OPTIONS CODES:

BODY MATERIAL

- A- Aluminum gage body (standard)
- B- Brass gage body (optional)
- S- Steel gage body (optional)
- Y- Stainless Steel gage body (optional)

SEAL MATERIAL

- 1- Buna N seals (standard)
- 2- Butyl seals (optional)
- 3- Viton® seals (optional)
- 4- Ethylene propylene seals (optional)
- 5- Silicone seals (optional)

SPECIFY PIPE THREAD SIZE:

- 2- 1/4 male pipe thread
- 3- 3/8 male pipe thread
- 4- 1/2 male pipe thread
- 5- 3/4 male pipe thread

G617 Series		
A	B	C
inches (mm)	inches (mm)	inches (mm)
5.00 (127.00)	3.50 (88.90)	6.62 (168.15)
6.00 (152.40)	4.50 (114.30)	7.62 (193.55)
7.00 (177.80)	5.50 (139.70)	8.62 (218.95)
8.00 (203.20)	6.50 (165.10)	9.62 (244.35)
9.00 (228.60)	7.50 (190.50)	10.62 (269.75)
10.00 (254.00)	8.50 (215.90)	11.62 (295.15)
12.00 (304.80)	10.50 (266.70)	13.62 (345.95)

Pipe Adapter		
D	E	F
NPTF	inches (mm)	inches (mm)
1/4-18	.56 (14.22)	1.19 (30.23)
3/8-18	.56 (14.22)	1.12 (28.45)
1/2-14	.75 (19.05)	1.12 (28.45)
3/4-14	.75 (19.05)	1.12 (28.45)

HOW TO ORDER

EXAMPLE:

G617-06-A-1-4 — 1/2 inch pipe thread
 — Buna N Seals
 — Aluminum gage body
 — 6.00 (152.40 mm) mounting centers
 — Series G617



Dimensions and specifications are subject to change without notice. Not all items are Made-To-Stock, contact us for availability.

02/14

Ph : 920-682-6877
 Fx : 920-684-7210



sales@ldi-industries.com
 www.ldi-industries.com