

# SIGHT GAGES - CLOSED CIRCUIT

## G619 SERIES

The heavy duty G619 Series front mount closed circuit sight gages provide front viewing of the fluid level clearly delineated by a redline on white background integral to the glass sight all secured within an aluminum body. A dry dial thermometer allows for temperature monitoring. The thermowell for the thermometer combines with the thermometer shield to serve as one of the mounting bolts for the sight gage. This construction allows the thermometer orientation to be adjusted independent of the sight gage and replaced without having to drain the reservoir. Installation is the similar to the G615 Series, but the robust construction of the G619 Series allows these gages to operate at higher working pressures.

### Standard Features:

- Front mount
- Fluid level visible from front of gage (.62 inch wide)
- Viewing enhanced by redline on white background integral to sight glass
- 1.38" diameter dual scale dial thermometer, 50° to 300°F and 10° to 150°C
- Dial thermometer may be removed from a filled reservoir without loss of fluid
- Suitable for use with most hydraulic and machine lubricating oils

### Standard Materials:

- Aluminum gage body and mounting bolt
- Buna N seals
- Borosilicate glass sight
- Zinc plated, steel hex nuts

### Temperature and Pressure Ratings:

- 600 psi (4137 kPa) maximum working pressure at 150°F (65°C) for centerline lengths from 4 to 12 inches (*Consult factory for pressure ratings on centerline lengths outside this range*)
- Please refer to Temperature Ratings by Seal Material for additional operating conditions (Appendix RA-5 on page RA-A5)

### NOTE:

- Please refer to Appendix RA-2 on page RA-A2 for installation instructions

**CAUTION:** • Not recommended for use with water, steam, acidic fluids, caustic fluids and volatile fluids

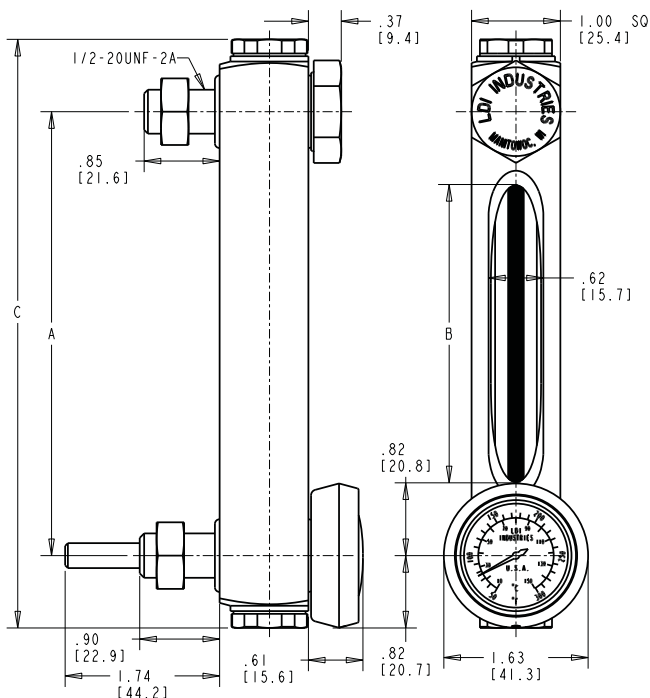

G619 Series				
Part No.	A inches (mm)	B inches (mm)	C inches (mm)	Max. Work. Pressure PSI (kPa)
G619-05-A-1	5.00 (127.00)	3.36 (85.34)	6.62 (168.15)	600 (4137)
G619-12-A-1	12.00 (304.80)	10.36 (263.14)	13.62 (345.95)	600 (4137)



**NOTE:** All dimensions are inches [mm]

### ORDERING OPTIONS CODES:

#### BODY MATERIAL

- A- Aluminum gage body (standard)
- B- Brass gage body (optional)
- S- Steel gage body (optional)
- Y- Stainless Steel gage body (optional)

#### SEAL MATERIAL

- 1- Buna N seals (standard)
- 2- Butyl seals (optional)
- 3- Viton® seals (optional)
- 4- Ethylene propylene seals (optional)
- 10- Neoprene seals (optional)

### HOW TO ORDER

#### EXAMPLE:

**G619-05-A-1** — Buna N Seals  
 Aluminum gage body  
 5.00 (127.00 mm) mounting centers  
 Series G619

Dimensions and specifications are subject to change without notice. Not all items are Made-To-Stock, contact us for availability.

02/14

Ph : 920-682-6877  
 Fx : 920-684-7210



sales@ldi-industries.com  
 www.ldi-industries.com