

SIGHT GAGES - CLOSED CIRCUIT

SGC SERIES

The SGC Series front mount closed circuit sight gages provide front viewing of the fluid level through a clear sight glass. Integral to the sight gage is a thermometer contained within a white colored card for direct reading of the fluid temperature. The white colored card helps draw eye contact to the fluid level quickly. Check valves integral to mounting studs allow for removal of sight gage without having to drain the reservoir.

Standard Features:

- Front mount
- Fluid level visible from front of gage (.75 inches wide)
- Clear sight glass
- Card thermometer, dual scale 0° to 220°F and -20° to 110°C graduations
- Mounting studs accommodate reservoir wall thicknesses up to .56 inches
- Suitable for use with most hydraulic and machine lubricating oils

Standard Materials:

- Aluminum & Brass Construction
- Buna N seals
- Borosilicate glass sight

Temperature and Pressure Ratings:

- 20 psi (138 kPa) maximum working pressure at 150°F (65°C)
- Please refer to Temperature Ratings by Seal Material for additional operating conditions (Appendix RA-5 on page RA-A5)

NOTES:

- Access to inside of reservoir is required to mount studs with integral check valves.
- Please refer to Appendix RA-11 on page RA-A10 for installation instructions

CAUTION: • Not recommended for use with water, steam, acidic fluids, caustic fluids and volatile fluids

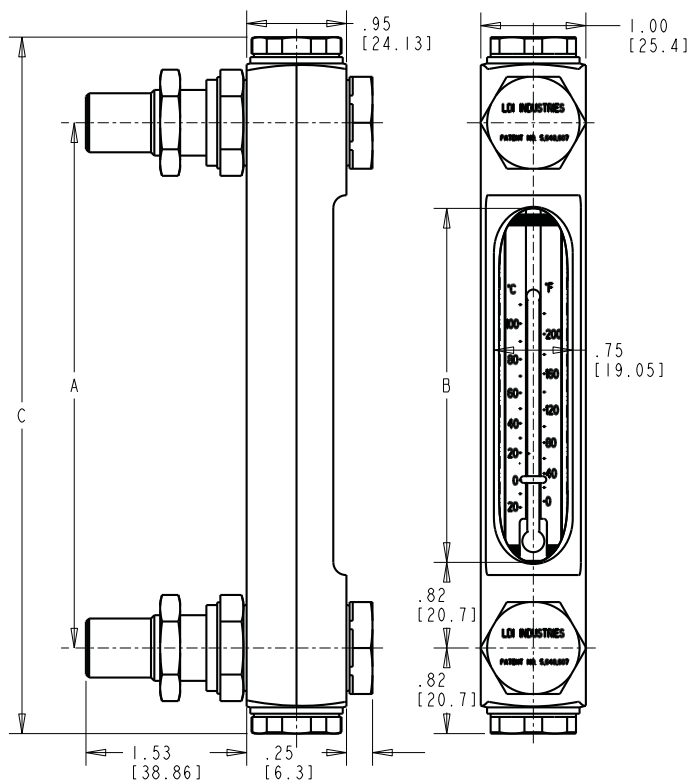

SGC Series			
Part No.	A Centers inches (mm)	B Sight inches (mm)	C Length inches (mm)
SGC5	5.00 (127.00)	3.50 (88.90)	6.62 (168.15)
SGC10	10.00 (254.00)	8.50 (215.90)	11.62 (295.15)



NOTE: All dimensions are inches [mm]

HOW TO ORDER

EXAMPLE:

SGC-10 — 10.00 inch (254.00 mm) mounting centers
Series SGC

When ordering, specify either 5.00 inch (127.00mm) or 10.00 inch (254.00mm) mounting centers following the series number, separated with a dash(-).

Dimensions and specifications are subject to change without notice. Not all items are Made-To-Stock, contact us for availability.

02/14

Ph : 920-682-6877
Fx : 920-684-7210



sales@ldi-industries.com
www.ldi-industries.com