

JIC TYPE RESERVOIRS

CONTAINMENT STAND

Containment stands with integral containment tray are an optional accessory to JIC type reservoirs to contain minor leaks or weepage from system components during normal operation. The stand feature provides for more convenient movement and placement of the system within the work place once assembled. Proper containment of fluids escaping from the system may help to limit contamination of the nearby environment and provide safer working conditions in areas otherwise negatively affected when exposed to the escaping fluid. Reservoirs are sold separately.

Standard Features:

1. Mate with JIC type reservoirs ranging in size from 10 to 500 gallons
2. (1) 3/4 inch NPT drain port with plug
3. Foot mounting pads (shipped loose)
4. Prime painted LDI gray
5. Material:
 - Carbon steel construction

- NOTE**
- Drain plugs need to be sealed and tightened before use
 - See page 16 for reservoir/containment stand assembly
 - Part numbers are for 6 inch high containment stands.
 - For 12 inch high containment stands, substitute -12 in part number - example: **DSA-10-12**

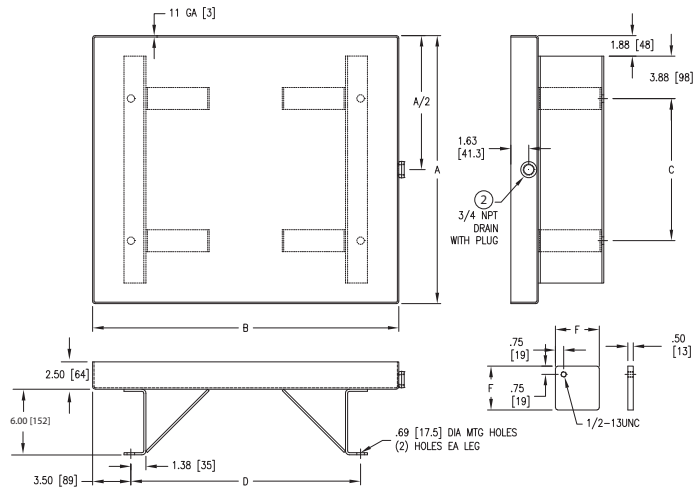

NOTE: All dimensions are inches [mm]

Reservoir Capacity (gal)	Part No.	Stand Dimensions (Inches)				Reservoir Type				Piece Weight (lbs)	
		A	B	C	D	Style A	Style B	Style RB	Style RT	6 inch	12 inch
10	DSA-10-6	24.50	28.00	13.00	21.00	•		•	•	72	91
15	DSA-15-6	24.50	32.00	13.00	25.00	•		•		72	91
20	DSA-20-6	24.50	36.00	13.00	29.00	•			•	80	99
20	DSB-20-6	27.50	38.00	16.00	31.00		•	•		91	113
30	DSA-30-6	30.50	42.00	19.00	35.00	•			•	104	127
35	DSA-30-6	30.50	42.00	19.00	35.00				•	104	127
40	DSA-30-6	30.50	42.00	19.00	35.00	•			•	104	127
50	DSA-30-6	30.50	42.00	19.00	35.00	•			•	104	127
60	DSA-60-6	33.50	54.00	22.00	47.00	•				130	155
60	DSB-60-6	31.50	44.00	20.00	37.00		•	•		110	135
70	DSA-60-6	33.50	54.00	22.00	47.00				•	130	155
80	DSA-80-6	33.50	66.00	22.00	59.00	•				144	180
80	DSB-80-6	36.50	53.00	25.00	46.00		•	•		138	171
90	DSA-80-6	33.50	66.00	22.00	59.00				•	148	184
100	DSA-80-6	33.50	66.00	22.00	59.00	•				148	184
100	DSB-80-6	36.50	53.00	25.00	46.00		•	•		142	181
120	DSA-120-6	36.50	66.00	25.00	59.00	•	•	•		161	190
130	DSA-120-6	36.50	66.00	25.00	59.00				•	161	190
150	DSA-120-6	36.50	66.00	25.00	59.00	•	•	•		160	189
160	DSA-120-6	36.50	66.00	25.00	59.00				•	160	189
200	DSA-200-6	42.50	78.00	31.00	71.00	•	•	•		205	238
210	DSA-200-6	42.50	78.00	31.00	71.00				•	205	238
250	DSA-200-6	42.50	78.00	31.00	71.00		•			205	238
300	DSA-200-6	42.50	78.00	31.00	71.00	•				205	238
300	*DSB-300-6	54.50	88.00	43.00	81.00		•	•		278	314
400	*DSA-400-6	54.50	78.00	43.00	71.00	•				256	298
500	*DSA-400-6	54.50	78.00	43.00	71.00	•				256	298

* 5 inch foot mounting pads for these part numbers.

FOOT MOUNTING PADS
F= 4 inches unless otherwise noted in chart



Note: For reservoir sizes not listed or custom sizes - consult factory

Dimensions and specifications are subject to change without notice. Not all items are Made-To-Stock, contact us for availability.

08/15

Ph : 920-682-6877
Fx : 920-684-7210



sales@ldi-industries.com
www.ldi-industries.com