

# LIQUID LEVEL GAGE - FRONT MOUNT, RIGID POLYMER

LDI INDUSTRIES' G623 series closed circuit liquid level gage is flush mounting, has a low profile and provides 180° viewing. This gage has a white insert strategically placed to provide a background for optimum fluid viewing. This economical gage is suitable for many applications that require maximum fluid level visibility. For gage with thermometer, see our Series GT623 on Bulletin F327-23B.

## STANDARD MATERIALS:

- Tough, break resistant, transparent rigid polymer sight offers wide angle viewing
- Steel, zinc plated mounting bolts
- Buna N seals
- Black powder coated steel guard

## OPERATING CONDITIONS:

- Maximum working pressure up to 100 PSIG (689 kPa) at 70°F (21.1°C)
- Maximum temperature up to 212°F (100°C)
- Suitable for use with most hydraulic and machine lubricating oils.

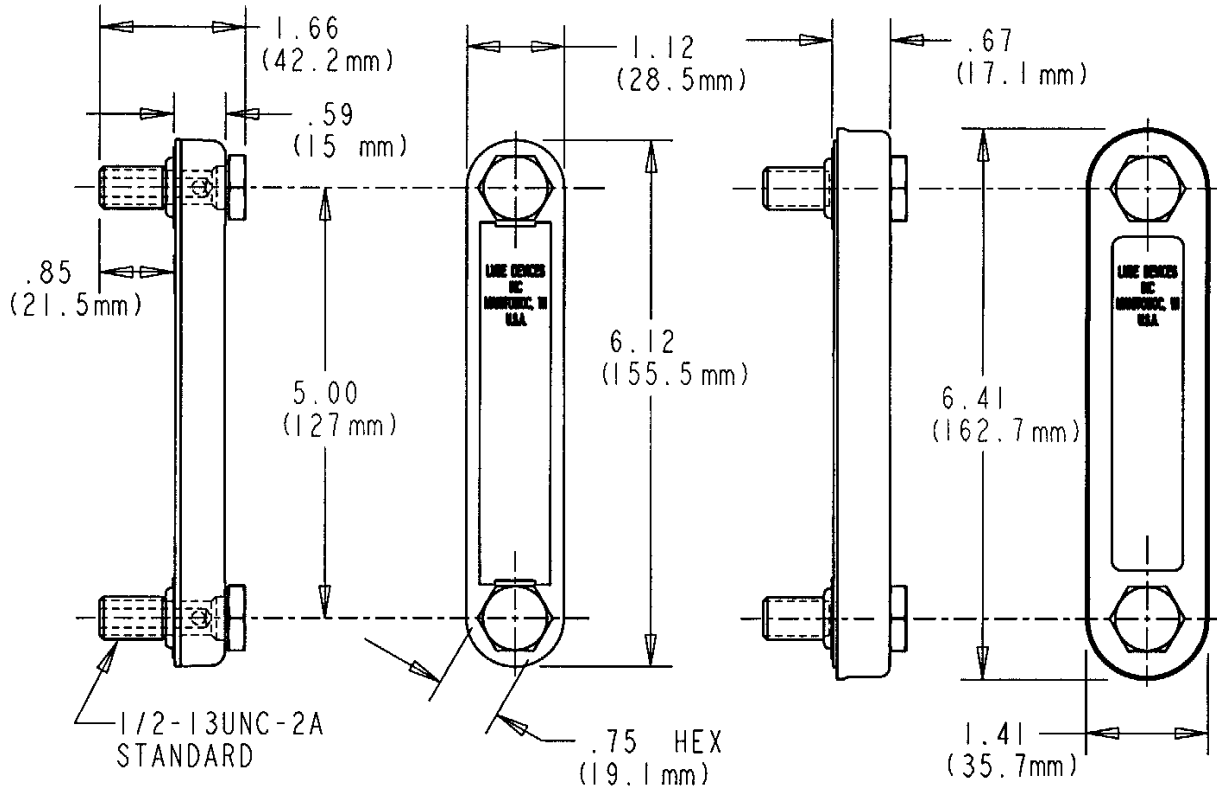

**NOTE:** Torque mounting bolts to 80 inch lbs. (9.04 N•m).

**WITH OPTIONAL GUARD**

## HOW TO ORDER:

**WHEN ORDERING, SPECIFY THE FOLLOWING AFTER THE SERIES NUMBER, SEPARATING EACH WITH A DASH (-):**

- 1- Buna N seals (standard)
- 3- Viton A® seals (optional)
- M M12 x 1.75 bolts (optional)
- G Guard (optional)

## EXAMPLE:

G623-05-PG-1C — 1/2-13 UNC bolts, std  
 — Buna N seals  
 — Guard  
 — Polymer body, std  
 — 5.00 (127mm) std mounting centers  
 — SERIES G623

**CAUTION: NOT RECOMMENDED FOR USE WITH:** Alcohol or Steam condensate. For these fluids, our gages with BOROSILICATE sight glass and appropriate seals should be specified.



Lube Devices • Flodar • Hydra-Tool • Vescor  
 1864 Nagle Ave. P. O. Box 1810  
 Manitowoc, WI 54221-1810  
 Phone: (920) 682-6877 Fax: (920) 684-7210  
 E-MAIL: sales@ldi-industries.com WEBSITE: www.ldi-industries.com

LIQUID LEVEL GAGE -  
 FRONT MOUNT, RIGID POLYMER  
**BULLETIN F327-23A**  
 5/06 **ISO9001:2000 CERTIFIED**