

BREATHER - STRAINER ASSEMBLY / SUMP STRAINER

Interchangeable 3.00 (76.20mm), 6.00 (152.40mm) and 8.00 (203.20mm) strainer permits easy fluid flow. Rapid filling and easy to clean. The breather cap has deep grip flutes for ease of removal. The removable twist lock breather cap is protected against loss by safety chain. Vented cap is standard, non-vented cap is available - **Please specify**. Cap and flange are plated for maximum corrosion resistance. Side mounted breather assembly housing is engineered for use with all strainer lengths. **FB113, FB116 and FB163** furnished with rigid inner guard (**FIG. B**).

All models complete with mounting bolts, nuts, lock washers, sealing washers and oil resistant composite gaskets.

STANDARD MATERIALS:

- Stainless steel strainer
- Zinc Clear plated breather cap
- Side mounted breather housing is anodized cast aluminum

OPERATING CONDITIONS:

- 30 mesh strainer
- 40 micron filter breather will handle 30 cu. ft. (.84 cu. m) of air per minute at differential pressure of less than 1.00 (25.40mm) Hg.

Top Mounting Catalog Number		Side Mounting Catalog Number		A Inches (mm)
Without Guard	With Guard	Without Guard	With Guard	
FB103	FB113	FB153	FB163	3.00 (76.20)
FB106	FB116	-	-	6.00 (152.40)
FB108	-	-	-	8.00 (203.20)

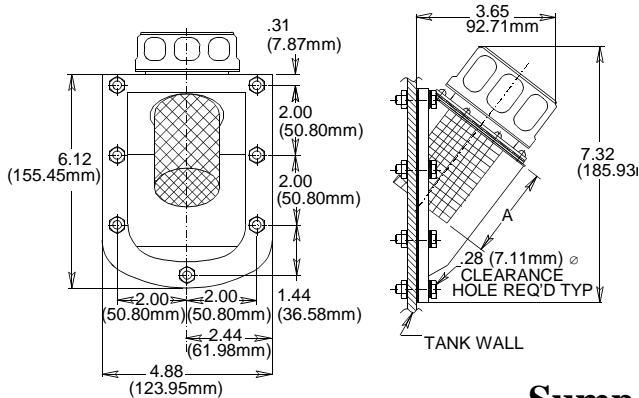
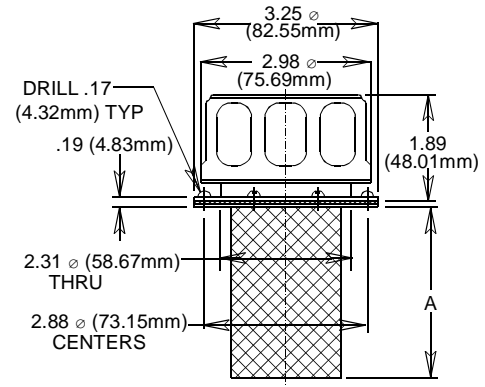

Sump Strainer

Rigid one piece inner frame prevents collapse. Wire screening is completely reusable and easily cleaned. Excellent flow through. Serves most filter requirements; suitable for most hydraulic oils, coolants and lubricants

STANDARD MATERIALS:

- Steel construction
- End plates and inner frame (see cutaway) are steel, zinc plated
- Stainless steel wire screening

OPERATING CONDITIONS:

- 5 to 30 GPM (18.9 to 113.6 LPM) range
- .2 PSI (1.38 kPa) pressure drop through clean Element at rated flow of 150 SSU viscosity oil

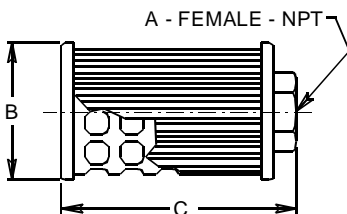

CATALOG NUMBER	A-NPT	B-DIA. INCHES(mm)	C-LENGTH INCHES (mm)	CAPACITY GPM (LPM)
100 MESH SCREEN				
SS5	1/2	2.62 (66.55)	3.12 (79.25)	5.0 (18.9)
SS8	3/4	2.62 (66.55)	3.50 (88.90)	8.0 (30.3)
SS10	1	2.62 (66.55)	5.41 (137.41)	10.0 (37.9)
SS20	1-1/4	3.41 (86.61)	6.91 (175.51)	20.0 (75.7)
SS30	1-1/2	3.41 (86.61)	7.91 (200.91)	30.0 (113.6)



Lube Devices • Flodar • Hydra-Tool • Vescor
 1864 Nagle Ave. P. O. Box 1810
 Manitowoc, WI 54221-1810
 Phone: (920) 682-6877 Fax: (920) 684-7210
 E-MAIL: sales@ldi-industries.com WEBSITE: www.ldi-industries.com

BREATHER - STRAINER ASSEMBLY
 SUMP STRAINER
 1/10 BULLETIN #1297-1
 ISO9001:2008 CERTIFIED