

# LIQUID LEVEL GAGE—FRONT MOUNT, DIAL PROBE THERMOMETER IN WELL

This gage can be installed from the front of the reservoir when wall is heavy enough to tap .500-20UNF thread or from the inside to tighten nuts. Exclusive design with a well protecting the sensing probe - allows removal of thermometer without loss of fluid. Easy reading dual scale dial thermometer has probe extending deep into reservoir and is not affected by ambient temperatures. Furnished complete - ready for installation. All "O" rings and hex nuts included. Available to 142.00 (3606.80mm) mounting centers per special order.

## STANDARD MATERIALS:

- Aluminum construction
- Buna N seals
- Borosilicate glass with redline on white background for distinct level reading and maximum fluid compatibility

## OPERATING CONDITIONS:

- See ENG. STD. 109

## HOW TO ORDER:

WHEN ORDERING, SPECIFY THE FOLLOWING AFTER THE SERIES NUMBER, SEPARATE EACH WITH A DASH (-). SELECT MOUNTING CENTERS. 3.00 (76.20mm) TO 12.00 (304.80mm) AVAILABLE FROM STOCK.

- A- Aluminum gage body (standard)
- B- Brass gage body (optional)
- S- Steel gage body (optional)
- Y- Stainless steel gage body (optional)
- 1- Buna N seals (standard)
- 2- Butyl seals (optional)
- 3- Viton A® seals (optional)
- 4- Ethylene propylene seals (optional)
- 5- Silicone seals (optional)

### EXAMPLE:

G645-10-A-1 — Buna N seals  
 — Aluminum gage body  
 — 10.00 (254.00mm) centers  
 — Series G645

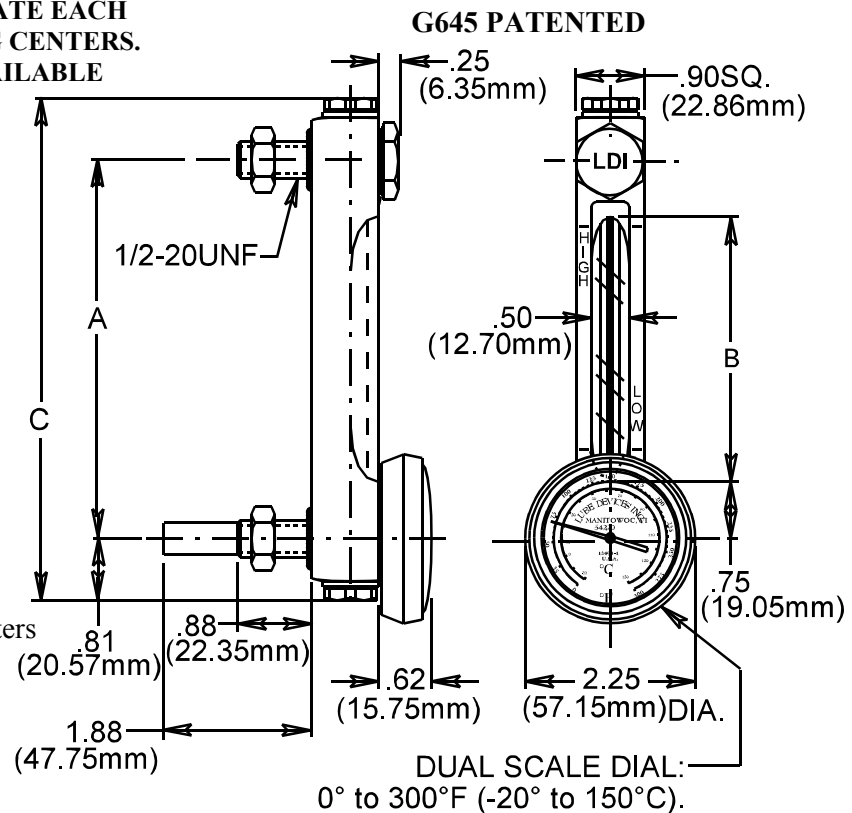

SERIES NUMBER	A - CENTERS INCHES (mm)	B - SIGHT INCHES (mm)	C - LENGTH INCHES (mm)
G645	05 (127.00)	3.50 (88.90)	6.62 (168.15)
	08 (203.20)	6.50 (165.10)	9.62 (244.35)
	10 (254.00)	8.50 (215.90)	11.62 (295.15)
	12 (304.80)	10.50 (266.70)	13.62 (345.95)

**MODIFICATIONS AVAILABLE MADE TO ORDER - CONSULT OUR FACTORY (MINIMUM ORDER MAY BE REQUIRED)**

LIQUID LEVEL GAGE-FRONT MOUNT  
 DIAL PROBE THERMOMETER IN WELL  
 4/03 **BULLETIN F327-45**



## LUBE DEVICES, INC.

1864 NAGLE AVE., P.O. BOX 1810, MANITOWOC, WI 54221-1810  
 PHONE: (920) 682-6877 FAX: (920) 684-7210  
 E-MAIL: sales@lubedevices.com WEBSITE: www.lubedevices.com