

NEEDLE VALVE MANIFOLD

Designed for controlled multiple oiling from central location. Lubricant, (in reservoir of dispenser) individually metered at valve bank, travels to various points servicing hard to get at places, and eliminating individual oil cups. Easily disassembled for cleaning, individual valves remove without disturbing other components.

● **PATENTED**

STANDARD MATERIALS:

- Aluminum construction
- Buna N Seals
- Gage glass sight

OPERATING CONDITIONS:

- Pressure applications up to 125 PSI (861.9 kPa) non-vented.
- Vacuum pressure available (requires modification) - **Please specify.**

**MODIFICATIONS AVAILABLE MADE TO ORDER - CONSULT OUR FACTORY
(MINIMUM ORDER MAY BE REQUIRED)**

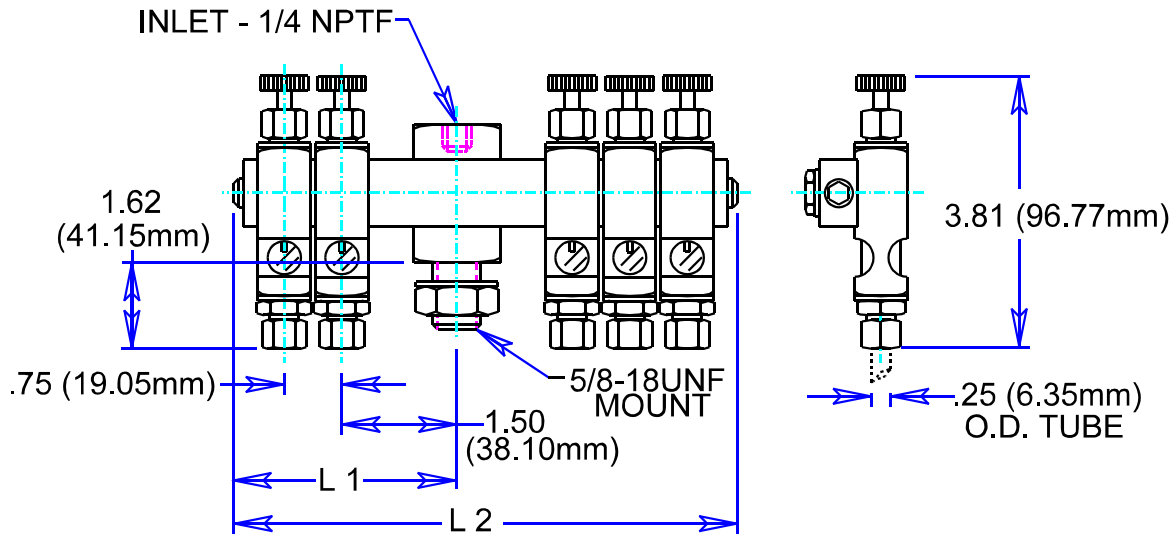

CATALOG NUMBER		FEEDS	L1 INCHES (mm)	L2 INCHES (mm)
GRAVITY VENTED SIGHT	PRESSURE NON-VENTED SIGHT			
NVM102-002	-102	2	2.09 (53.09)	4.19 (106.43)
NVM102-003	-103	3	2.09 (53.09)	4.94 (125.48)
NVM102-004	-104	4	2.84 (72.14)	5.69 (144.53)
NVM102-005	-105	5	2.84 (72.14)	6.44 (163.58)
NVM102-006	-106	6	3.59 (91.19)	7.19 (182.63)
NVM102-008	-108	8	4.34 (110.24)	8.69 (220.73)



LUBE DEVICES, INC.

1864 NAGLE AVE., P.O. BOX 1810, MANITOWOC, WI 54221-1810
 PHONE: (920) 682-6877 FAX: (920) 684-7210
 E-MAIL: sales@lubedevices.com WEBSITE: www.lubedevices.com

NEEDLE VALVE MANIFOLD

9/03 **BULLETIN F577-1**