

# LUBE SIGHT CHECK- LOW PRESSURE-HOLE MOUNT

Hole mount sight checks are an inexpensive way to check fluid level in a reservoir. They require access to the interior to tighten the nuts. May be positioned at top and bottom to indicate high and low fluid levels.

**CAUTION:** Scratched glass significantly reduces pressure rating.

**STANDARD MATERIALS: OPERATING CONDITIONS:**

- Aluminum construction
- Stainless steel reflector
- Buna N seals
- Glass sight
- Maximum operating temperature up to 180°F (82.2°C). For applications requiring maximum operating temperatures over 180°F (82.2°C), please consult factory.

**MODIFICATIONS:**

- **Body** - Brass, steel, stainless steel
- **Seals** - Butyl, Viton A®, EPDM, high temperature
- **Sight** - Polycarbonate, borosilicate
- **Ball** - Nylon, polyethylene

**MODIFICATIONS AVAILABLE - MADE TO ORDER - CONSULT OUR FACTORY  
(MINIMUM ORDER MAY BE REQUIRED)**

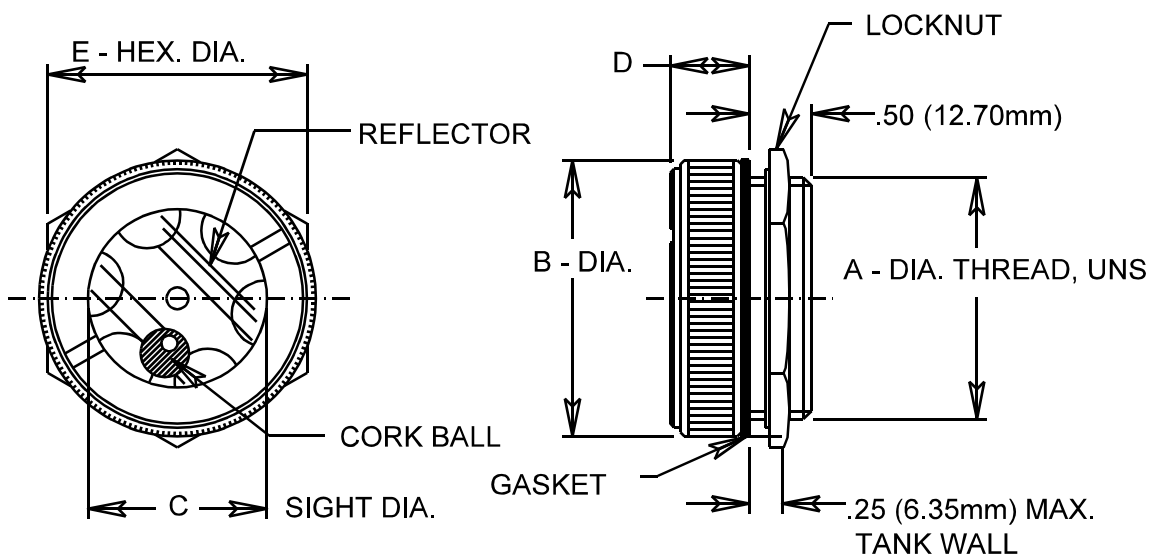

CATALOG NUMBER			A UNS	B INCHES (mm)	C INCHES (mm)	D INCHES (mm)	E INCHES (mm)	MAXIMUM WORKING PSI (kPa) @69°F(20.6°C)
OPEN VIEW	REFLECTOR	REFLECTOR WITH BALL						
LSP101-04	LSP101-04-01	LSP101-04-02	3/4-27	1.00 (25.40)	.56 (14.22)	.44 (11.18)	.88 (22.35)	50 (345)
LSP101-06	LSP101-06-01	LSP101-06-02	1-24	1.25 (31.75)	.75 (19.05)	.44 (11.18)	1.12 (28.45)	50 (345)
LSP101-08	LSP101-08-01	LSP101-08-02	1-1/4-24	1.50 (38.10)	.97 (24.64)	.44 (11.18)	1.38 (35.05)	25 (172)
LSP101-13	LSP101-13-01	LSP101-13-02	1-7/8-24	2.12 (53.85)	1.38 (35.05)	.62 (15.75)	2.00 (50.80)	25 (172)
LSP101-17	LSP101-17-01	LSP101-17-02	2-3/8-24	2.62 (66.55)	1.88 (47.75)	.62 (15.75)	2.62 (66.55)	10 (69)

LUBE SIGHT CHECK-  
LOW PRESSURE - HOLE MOUNT  
5/02 BULLETIN F677-3



**LUBE DEVICES, INC.**

1864 NAGLE AVE., P.O. BOX 1810, MANITOWOC, WI 54221-1810  
PHONE: (920) 682-6877 FAX: (920) 684-7210  
E-MAIL: sales@lubedevices.com WEBSITE: www.lubedevices.com