

4

3

2

1

DWG. NO. V100700

NOTES:

- 1. THIS RESERVOIR IS DESIGNED FOR STATIONARY INSTALLATIONS, ANY MOBILE INSTALLATIONS ARE SUBJECT TO FACTORY REVIEW.
- 2. DO NOT SHIP THIS UNIT FULL OF OIL (APPLIES TO 50+ GALLON RESERVOIRS).
- 3. THIS RESERVOIR IS THOROUGHLY CLEANED, A RUST INHIBITOR APPLIED TO THE INTERIOR AND PRIME PAINTED GRAY PRIOR TO SHIPMENT. ANY SUBSEQUENT CUTTING OR WELDING ON THE UNIT COULD CAUSE CONTAMINATION AND WILL VOID THE WARRANTY.
- 4. OPERATING TEMPERATURE IS 180° F MAXIMUM. FOR HIGHER TEMPERATURES CONSULT FACTORY.
- 5. ALL PORTS ARE PLASTIC PLUGGED AND PROTECTED FOR SHIPPING. LEAVE THESE IN PLACE UNTIL THE UNIT IS FINAL PAINTED OR FINISH ASSEMBLED. IF PAINTED AFTER ASSEMBLY, PLUG AND PROTECT ALL OPENINGS INTO THE RESERVOIR.
- 6. SHIPPED LOOSE: SIGHT GLASS (ALUMINUM WITH BUNA N SEALS)  
FILLER/BREATHER (STEEL WITH ZINC TRIVALENT CHROME FINISH)
- 7. RECOMMENDED ASSEMBLY TORQUE: ENDCOVER (15 FT LB), SIGHT GLASS (60 IN LB)

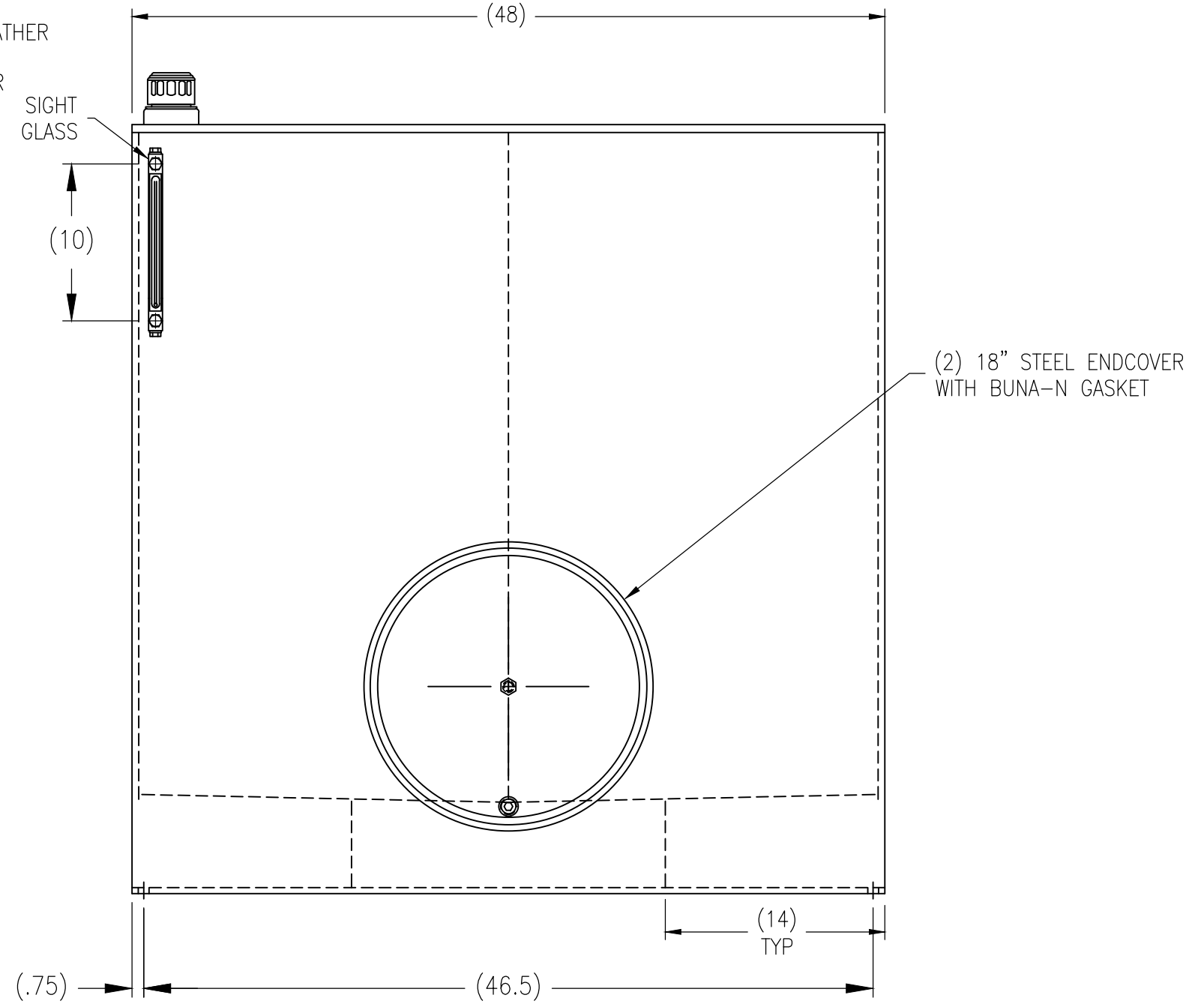
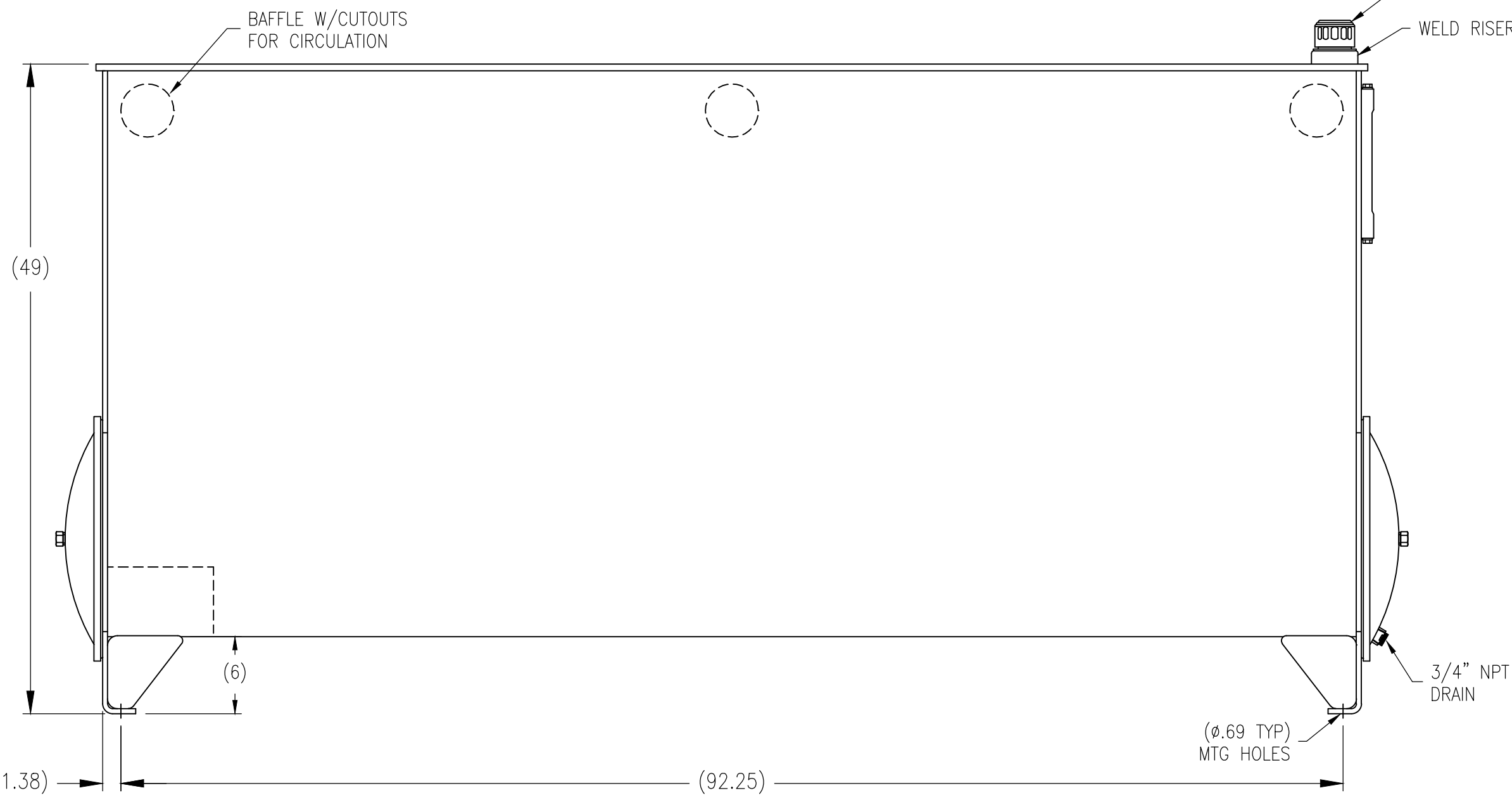

THIS DOCUMENT CONTAINS INFORMATION PROPRIETARY TO LDI Industries, Inc. AND IS FURNISHED UPON THE EXPRESS CONDITION THAT THE INFORMATION CONTAINED HEREIN WILL NOT BE DISCLOSED TO ANY THIRD PARTY OR USED DIRECTLY OR INDIRECTLY IN ANY WAY DETRIMENTAL TO THE INTEREST OF LDI Industries, Inc.



TITLE RES\_STYLE\_A\_700GAL\_STL\_PRIME  
LDI STANDARD RESERVOIR

DWG NO./ITEM NO. V100700

DRWN RKL DATE 03/09/13 CHKD - DATE - SHT 1/1 REV -

MATERIAL	STEEL	TOLERANCES	UNLESS OTHERWISE SPECIFIED
FINISH	SEE NOTES	( ) REFERENCE DIMENSIONS	
NOM WT (LBS.)	19960.0	SCALE	7/64
REV	DATE	ECN NO.	BY
-	-	-	-

4

3

2

1

D

C

B

A

D

C

B

A