

NOTES:

1. INTERIOR SURFACES ARE COATED WITH OIL
2. ACCESSORIES TO SHIP LOOSE
3. DOWN PIPES ARE APPROX 1.50 OFF BOTTOM AND HAVE A MITRED END
4. GENERAL LOCATION TOL IS +/- .12, FLANGE PATTERNS AND TAP TOL IS +/- .06
5. SAE PORTS TO BE OUTSIDE TANK
6. STD SIGHT GAGE IS MOLDED NYLON (5.00) WITH METAL GUARD
7. ALL STD SEALS ARE NITRILE
8. ALL DIMENSIONS ARE IN INCHES AND FOR REFERENCE ONLY
9. SEE SHEET 2 FOR ADDITIONAL OPTIONS & LOCATIONS

# EZ MOD

Custom Reservoirs - *Fast*

## STYLE A SERIES

SPECIFY (CIRCLE)			
TANK SIZE (GAL)	QTY	FINISH	
20 30 <b>40</b> 50 60	<b>1</b> 2 3	UNPAINTED	<b>GRAY PRIMER</b> GRAY PAINT BLACK PAINT

GENERAL OPTIONS (CIRCLE)			
MOVE SIGHT GAGE LOCATION	A	B	C
CHANGE SIGHT GAGE TO ALUM MATERIAL	<b>5.00</b>	10.00	(CENTERLINE)
CHANGE SEAL MATERIAL	EPDM (5.00 ALUM ONLY)		
ADD LIFTING LUGS	TOP	ENDS	

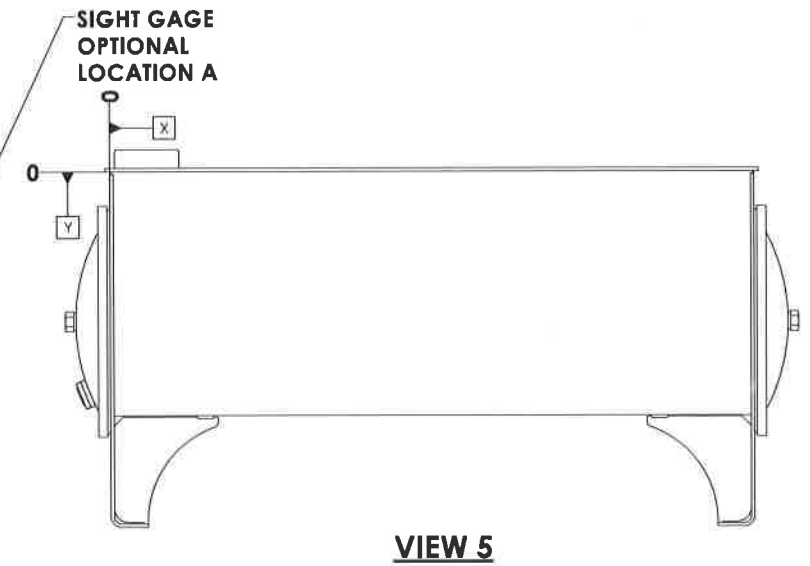
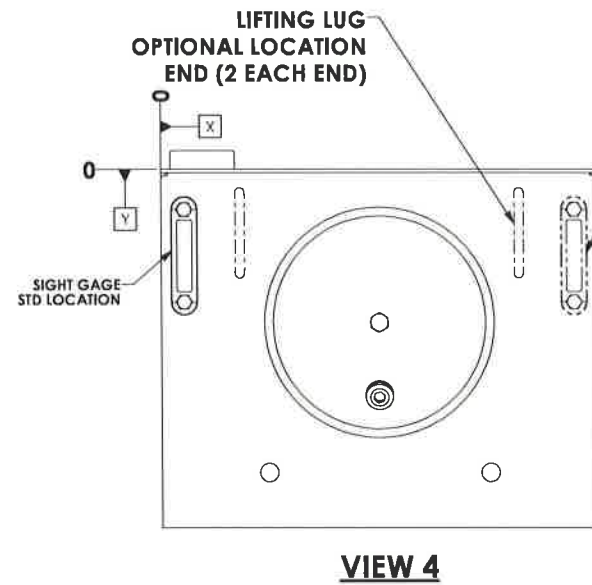
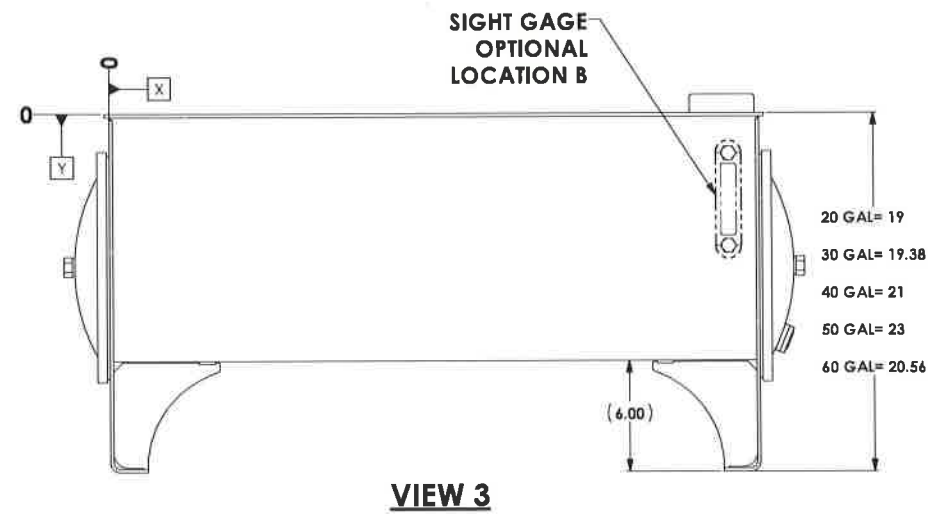
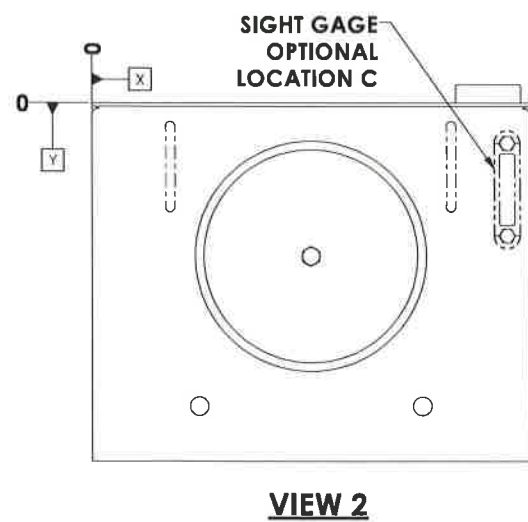
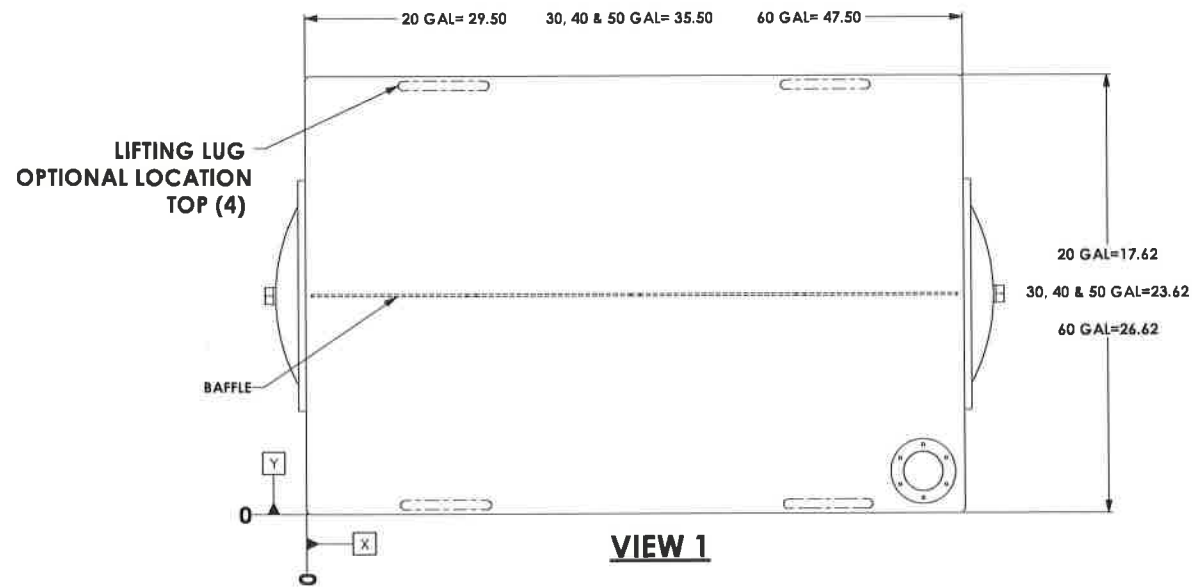

VIEW 1 MODIFICATION OPTIONS (CIRCLE)				LOCATION	
OPTIONS	NPT	SAE	SAE x NPT	X	Y
HALF CPLG	1/2 3/4 1 1-1/4	-8 -10 -12 -16			
	1-1/2 2 2-1/2 3	-20 -24 -32			
	1/2 3/4 1 1-1/4	-8 -10 -12 -16			
	1-1/2 2 2-1/2 3	-20 -24 -32			
FULL CPLG	1/2 3/4 1 1-1/4	-8 -10 -12 -16	-8x1/2 -10x3/4 -12x3/4 -16x1	18 1/4	13 1/16
	1-1/2 2 2-1/2 3	-20 -24 -32	-20x1-1/4 -24x1-1/2 -32x2		
	1/2 3/4 1 1-1/4	-8 -10 -12 -16	-8x1/2 -10x3/4 -12x3/4 -16x1		
	1-1/2 2 2-1/2 3	-20 -24 -32	-20x1-1/4 -24x1-1/2 -32x2		
FULL CPLG WITH DOWNPIPE	1/2 3/4 1 1-1/4 1-1/2 2		-8x1/2 -10x3/4 -12x3/4 -16x1 -20x1-1/4 -24x1-1/2 -32x2		
	1/2 3/4 1 1-1/4 1-1/2 2		-8x1/2 -10x3/4 -12x3/4 -16x1 -20x1-1/4 -24x1-1/2 -32x2		
	1/2 3/4 1 1-1/4 1-1/2 2		-8x1/2 -10x3/4 -12x3/4 -16x1 -20x1-1/4 -24x1-1/2 -32x2		
HOLE 1	7/8 DIA			22 1/4	13 1/16
HOLE 2	1 1/2 DIA			27 3/4	6 1/16
HOLE 3	4 DIA			3 1/4	20 5/16
OPTIONS	PIPE OR TUBE (CIRCLE)	PART # (SPECIFY)	ORIENTATION	LOCATION	
SUCTION FLANGE CUTOUT (ONE ONLY)	PIPE: 1/2 3/4 1 1-1/4 1-1/2 2 2-1/2 3 3 3-1/2 4			X	Y
	TUBE: 3/8 1/2 5/8 3/4 1 1-1/4 1-1/2				
RETURN FLANGE CUTOUT (ONE ONLY)	PIPE: 1/2 3/4 1 1-1/4 1-1/2 2		(CIRCLE ONE) 		
	TUBE: 3/8 1/2 5/8 3/4 1 1-1/4 1-1/2 2				

VIEW 2 MODIFICATION OPTIONS (CIRCLE)				LOCATION	
OPTIONS	NPT	SAE	SAE x NPT	X	Y
HALF CPLG	1/2 3/4 1 1-1/4	-8 -10 -12 -16			
	1-1/2 2 2-1/2 3	-20 -24 -32			
FULL CPLG	1/2 3/4 1 1-1/4	-8 -10 -12 -16	-8x1/2 -10x3/4 -12x3/4 -16x1		
	1-1/2 2 2-1/2 3	-20 -24 -32	-20x1-1/4 -24x1-1/2 -32x2		
	1/2 3/4 1 1-1/4	-8 -10 -12 -16	-8x1/2 -10x3/4 -12x3/4 -16x1		
FULL CPLG WITH DOWNPIPE	1/2 3/4 1 1-1/4 1-1/2 2		-8x1/2 -10x3/4 -12x3/4 -16x1 -20x1-1/4 -24x1-1/2 -32x2		
	1/2 3/4 1 1-1/4 1-1/2 2		-8x1/2 -10x3/4 -12x3/4 -16x1 -20x1-1/4 -24x1-1/2 -32x2		
HOLE 1	DIA				
HOLE 2	DIA				
OPTIONS	NPT	SAE	SAE x NPT	X	Y
HALF CPLG	1/2 3/4 1 1-1/4	-8 -10 -12 -16		23 1/2	12 1/4
	1-1/2 2 2-1/2 3	-20 -24 -32			
	1/2 3/4 1 1-1/4	-8 -10 -12 -16			
FULL CPLG	1/2 3/4 1 1-1/4	-8 -10 -12 -16	-8x1/2 -10x3/4 -12x3/4 -16x1		
	1-1/2 2 2-1/2 3	-20 -24 -32	-20x1-1/4 -24x1-1/2 -32x2		
	1/2 3/4 1 1-1/4	-8 -10 -12 -16	-8x1/2 -10x3/4 -12x3/4 -16x1		
FULL CPLG WITH DOWNPIPE	1/2 3/4 1 1-1/4 1-1/2 2		-8x1/2 -10x3/4 -12x3/4 -16x1 -20x1-1/4 -24x1-1/2 -32x2		
	1/2 3/4 1 1-1/4 1-1/2 2		-8x1/2 -10x3/4 -12x3/4 -16x1 -20x1-1/4 -24x1-1/2 -32x2		
HOLE 1	DIA				
HOLE 2	DIA				
OPTIONS	NPT	SAE	SAE x NPT	X	Y
HALF CPLG	1/2 3/4 1 1-1/4	-8 -10 -12 -16			
	1-1/2 2 2-1/2 3	-20 -24 -32			
	1/2 3/4 1 1-1/4	-8 -10 -12 -16			
FULL CPLG	1/2 3/4 1 1-1/4	-8 -10 -12 -16	-8x1/2 -10x3/4 -12x3/4 -16x1		
	1-1/2 2 2-1/2 3	-20 -24 -32	-20x1-1/4 -24x1-1/2 -32x2		
	1/2 3/4 1 1-1/4	-8 -10 -12 -16	-8x1/2 -10x3/4 -12x3/4 -16x1		
FULL CPLG WITH DOWNPIPE	1/2 3/4 1 1-1/4 1-1/2 2		-8x1/2 -10x3/4 -12x3/4 -16x1 -20x1-1/4 -24x1-1/2 -32x2		
	1/2 3/4 1 1-1/4 1-1/2 2		-8x1/2 -10x3/4 -12x3/4 -16x1 -20x1-1/4 -24x1-1/2 -32x2		
HOLE 1	DIA				
HOLE 2	DIA				
OPTIONS	NPT	SAE	SAE x NPT	X	Y
HALF CPLG	1/2 3/4 1 1-1/4	-8 -10 -12 -16			
	1-1/2 2 2-1/2 3	-20 -24 -32			
	1/2 3/4 1 1-1/4	-8 -10 -12 -16			
FULL CPLG	1/2 3/4 1 1-1/4	-8 -10 -12 -16	-8x1/2 -10x3/4 -12x3/4 -16x1		
	1-1/2 2 2-1/2 3	-20 -24 -32	-20x1-1/4 -24x1-1/2 -32x2		
	1/2 3/4 1 1-1/4	-8 -10 -12 -16	-8x1/2 -10x3/4 -12x3/4 -16x1		
FULL CPLG WITH DOWNPIPE	1/2 3/4 1 1-1/4 1-1/2 2		-8x1/2 -10x3/4 -12x3/4 -16x1 -20x1-1/4 -24x1-1/2 -32x2		
	1/2 3/4 1 1-1/4 1-1/2 2		-8x1/2 -10x3/4 -12x3/4 -16x1 -20x1-1/4 -24x1-1/2 -32x2		
HOLE 1	DIA				
HOLE 2	DIA				

1. SUCTION AND RETURN FLANGES ARE SOLD SEPARATELY