

BREATHERS & FILLER BREATHERS

MINIATURE BREATHER — POLYMER W/FILTER

LDI Miniature Tank Breathers are designed to replace more costly, less efficient breathers and to improve the filtering performance of the breather vent.

Standard Features:

- 40 micron air filtration
- Gray cap for high visibility

PMB Series Features

- Suitable for use on hydraulic power packs or tanks subject to change in liquid volume

SGB Series Features

- Splash guard that prevents oil loss
- Suitable for use where oil is violently agitated and could be splashed against breather cap

Standard Material:

- Polyamide based technopolymer cap

Temperature Rating:

- -22°F (-30°C) to 212°F (100°C)

Mounting Information:

- PMB/SGB-02-10 - Any standard 1/4 inch NPT (female) threaded pipe port
- PMB/SGB-05-10 - Any standard 3/8 inch NPT (female) threaded pipe port
- PMB/SGB-03-10 - Any standard 1/2 inch NPT (female) threaded pipe port
- PMB/SGB-07-10 - Any standard 3/4 inch NPT (female) threaded pipe port

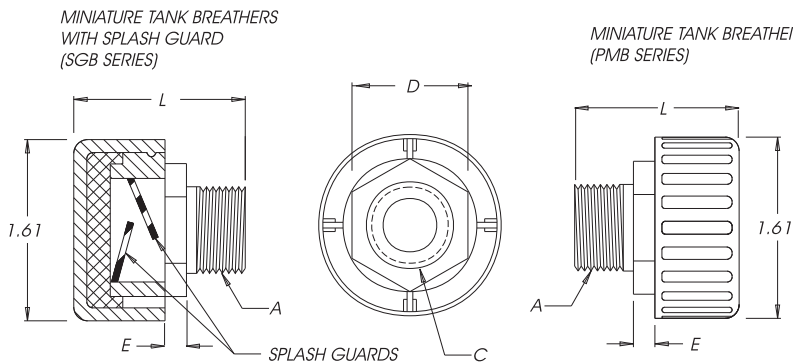

NOTE: All dimensions are inches

PMB and SGB Series - Technical & Dimensional Details

Part No.	A NPT	C Hole Dia	D Hex	E Flat	L Overall Length	Splash Guard
PMB-02-10	1/4	.27	.62	.27	1.53	No
PMB-05-10	3/8	.31	.75	.27	1.73	No
PMB-03-10	1/2	.47	1.00	.27	1.85	No
PMB-07-10	3/4	.70	1.13	.27	1.85	No
SGB-02-10	1/4	.27	.62	.27	1.53	Yes
SGB-05-10	3/8	.31	.75	.27	1.75	Yes
SGB-03-10	1/2	.47	1.00	.27	1.85	Yes
SGB-07-10	3/4	.70	1.13	.27	1.85	Yes

Dimensions and specifications are subject to change without notice. Not all items are Made-To-Stock, contact us for availability.

07/21

Ph : 920-682-6877
Fx : 920-684-7210



sales@ldi-industries.com
www.ldi-industries.com