

SIGHT PLUGS

LSP101 SERIES

The LSP101 Series low pressure aluminum sight plug inserts through a clearance hole and utilizes a lock nut assembled from within the reservoir to seal on a flange gasket. A clear glass sight provides good open view visibility with options to further enhance visibility by accessorizing the sight plug with combinations of reflector and float ball options. Access to inside of reservoir is required to secure the lock nut. Box quantities may apply.

Standard Feature:

- Clear glass sight

Standard Materials:

- Aluminum construction
- Buna N seals
- Soda lime glass sight
- Stainless Steel reflector (when applicable)
- Cork float ball

Temperature and Pressure Ratings:

- Maximum operating temperature up to 180°F (82°C).
(For applications requiring maximum operating temperatures in excess of 180°F (82°C), consult factory for available options.)
- See chart below for pressure ratings

- CAUTION:**
- Do not use an impact wrench to install a sight plug
 - Not recommended for steam applications
 - Scratched glass significantly reduces the pressure rating of the sight plug

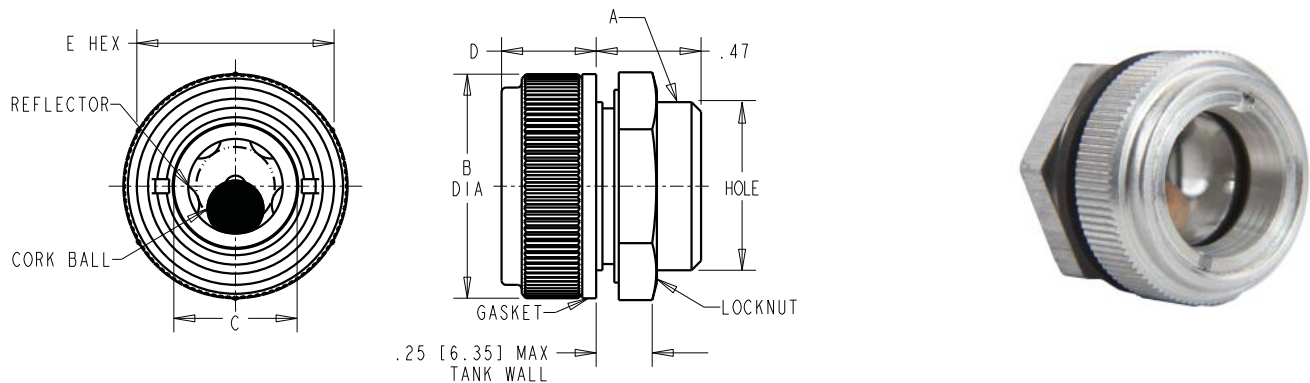

NOTE: All dimensions are inches (mm)

LSP101 Series										
Open View	Part No. Reflector	Reflector and Ball	Min/Mult Box Quantity	A	Hole Dia* inches (mm)	B inches (mm)	C inches (mm)	D inches (mm)	E inches (mm)	Max. Work. Pressure @ 69° F (20° C) PSI (kPa)
LSP101-04	LSP101-04-01	LSP101-04-02	25	3/4-27	.75 (19.05)	1.00 (25.40)	.55 (13.97)	.42 (10.67)	.88 (22.35)	50 (345)
LSP101-06	LSP101-06-01	LSP101-06-02	25	1-24	1.00 (25.40)	1.25 (31.75)	.75 (19.05)	.42 (10.67)	1.12 (28.45)	50 (345)
LSP101-08	LSP101-08-01	LSP101-08-02	15	1 1/4-24	1.25 (31.75)	1.50 (38.10)	.94 (23.88)	.42 (10.67)	1.38 (35.05)	25 (172)
LSP101-13	LSP101-13-01	LSP101-13-02	10	1 7/8-24	1.88 (47.75)	2.12 (53.85)	1.38 (35.05)	.62 (15.75)	2.00 (50.80)	25 (172)
LSP101-17	LSP101-17-01	LSP101-17-02	10	2 3/8-24	2.38 (60.45)	2.62 (66.55)	1.88 (47.75)	.62 (15.75)	2.62 (66.55)	10 (69)

* tolerance +.02/-.00 (+0.5/-0.00)

Dimensions and specifications are subject to change without notice. Not all items are Made-To-Stock, contact us for availability.

11/16

Ph : 920-682-6877
Fx : 920-684-7210



sales@ldi-industries.com
www.ldi-industries.com